



Managing the risk of falls at workplaces code of practice

April 2016



SafeWork NSW

NSW note: This code is based on a national model code of practice developed by Safe Work Australia under the harmonisation of national work health and safety legislation and has been approved under section 274 of the NSW *Work Health and Safety Act 2011*. Notice of that approval was published in the NSW Government Gazette referring to this code of practice as *How to prevent falls at the workplace* (page 7194) on Friday 16 December 2011. This code of practice commenced on 1 January 2012. Subsequent amendments under section 274 (2) of the NSW *Work Health and Safety Act 2011* have been published and commenced as detailed in the list of amendments contained in this code.

ISBN 978-0-642-33297-4 [PDF]

ISBN 978-0-642-33298-1 [RTF]

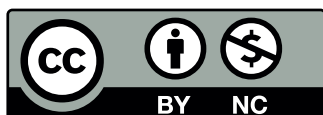

Creative Commons

Except for the SafeWork NSW logo, this copyright work is licensed under a Creative Commons Attribution-Noncommercial 3.0 Australia licence. To view a copy of this licence, visit creativecommons.org/licenses/by-nc/3.0/au/

In essence, you are free to copy, communicate and adapt the work for non commercial purposes, as long as you attribute the work to Safe Work Australia and abide by the other licence terms.

Contents

Foreword	2
Scope and application	2
1. Introduction	3
1.1 Who has health and safety duties in relation to falls?	3
1.2 The meaning of key terms	3
1.3 What is required to manage the risk of falls?	4
2. Managing the risk of falls	6
2.1 How to identify fall hazards	6
2.2 How to assess the risk	7
2.3 How to control the risk	7
2.4 How to review control measures	9
3. Work on the ground or on a solid construction	10
3.1 Work on the ground	10
3.2 Work on a solid construction	11
4. Fall prevention devices	14
4.1 Temporary work platforms	14
4.2 Perimeter guard rails	21
4.3 Safety mesh	21
5. Work positioning systems	22
5.1 Industrial rope access systems	22
5.2 Restraint technique	23
6. Fall-arrest systems	25
6.1 Catch platforms	25
6.2 Industrial safety nets	26
6.3 Individual fall-arrest systems	26
6.4 Anchorage lines or rails	30
7. Ladders	32
7.1 Portable ladders	32
7.2 Fixed ladders	36
7.3 Ladder maintenance	37
8. Administrative controls	38
9. Emergency procedures for falls	40
9.1 Emergency procedures	40
9.2 Suspension intolerance	41
10. Design of plant and structures	42
10.1 Design considerations	42
10.2 Plant	42
10.3 Buildings and structures	43
Appendix A: Terms used in fall control measures	45
Appendix B: References and other information sources	46
List of amendments	47

Foreword

This Code of Practice on how to manage the risk of falls in the workplace is an approved code of practice under section 274 of the *Work Health and Safety Act* (the WHS Act).

An approved code of practice is a practical guide to achieving the standards of health, safety and welfare required under the WHS Act and the Work Health and Safety Regulations (the WHS Regulations).

A code of practice applies to anyone who has a duty of care in the circumstances described in the code. In most cases, following an approved code of practice would achieve compliance with the health and safety duties in the WHS Act, in relation to the subject matter of the code. Like regulations, codes of practice deal with particular issues and do not cover all hazards or risks that may arise. The health and safety duties require duty holders to consider all risks associated with work, not only those for which regulations and codes of practice exist.

Codes of practice are admissible in court proceedings under the WHS Act and Regulations. Courts may regard a code of practice as evidence of what is known about a hazard, risk or control and may rely on the code in determining what is reasonably practicable in the circumstances to which the code relates.

Compliance with the WHS Act and Regulations may be achieved by following another method, such as a technical or an industry standard, if it provides an equivalent or higher standard of work health and safety than the code.

An inspector may refer to an approved code of practice when issuing an improvement or prohibition notice.

This Code of Practice has been developed by Safe Work Australia as a model code of practice under the Council of Australian Governments' Inter-Governmental Agreement for Regulatory and *Operational Reform in Occupational Health and Safety* for adoption by the Commonwealth, state and territory governments.

A draft of this Code of Practice was released for public consultation on 7 December 2010 and was endorsed by the Workplace Relations Ministers' Council on 10 August 2011.

Scope and application

This Code applies to all workplaces covered by the WHS Act and Regulations where there is a risk of a fall by a person from one level to another that is reasonably likely to cause injury.

This Code provides practical guidance to persons conducting a business or undertaking, including those persons who design, construct, import, supply or install plant or structures, on how to manage health and safety risks arising from falls. It includes information on a range of control measures to eliminate or minimise the risks.

How to use this Code of Practice

In providing guidance, the word 'should' is used in this Code to indicate a recommended course of action, while 'may' is used to indicate an optional course of action.

This Code also includes various references to sections of the WHS Act and Regulations which set out the legal requirements. These references are not exhaustive. The words 'must', 'requires' or 'mandatory' indicate that a legal requirement exists and must be complied with.

1. Introduction

Falls are a major cause of death and serious injury in Australian workplaces. Fall hazards are found in many workplaces where work is carried out at height, for example stacking shelves, working on a roof, unloading a large truck or accessing silos. Falls can also occur at ground level into holes, for example trenches or service pits.

1.1 Who has health and safety duties in relation to falls?

A person conducting a business or undertaking has the primary duty under the WHS Act to ensure, as far as reasonably practicable, that workers and other persons are not exposed to health and safety risks arising from the business or undertaking.

A person conducting a business or undertaking has more specific obligations under the WHS Regulations to manage the risk of a fall by a person from one level to another, including requirements to:

- ensure, so far as is reasonably practicable, that any work involving the risk of a fall is carried out on the ground or on a solid construction
- provide safe means of access to and exit from the workplace
- minimise the risk of falls so far as is reasonably practicable by providing a fall prevention device, work positioning system or a fall arrest system.

Designers, manufacturers, suppliers, importers and installers of plant or structures that could be used for work must ensure, so far as is reasonably practicable, that the plant or structure is without risks to health and safety. Designers of plant or structures have an important role in eliminating or minimising the risks of falls in the design stage (see Chapter 10 of this Code).

Officers, such as company directors, have a duty to exercise due diligence to ensure that the business or undertaking complies with the WHS Act and Regulations. This includes taking reasonable steps to ensure that the business or undertaking has and uses appropriate resources and processes to eliminate or minimise risks of falls from one level to another that are likely to cause injury.

Workers have a duty to take reasonable care for their own health and safety and that they do not adversely affect the health and safety of other persons. Workers must comply with any reasonable instruction given by the person conducting the business or undertaking.

1.2 The meaning of key terms

Fall means a fall by a person from one level to another.

Risk of a fall means a circumstance that exposes a worker while at work, or other person while at or in the vicinity of a workplace, to a risk of a fall that is reasonably likely to cause injury to the worker or other person. This includes circumstances in which the worker or other person is:

- in or on plant or a structure that is at an elevated level
- in or on plant that is being used to gain access to an elevated level
- in the vicinity of an opening through which a person could fall
- in the vicinity of an edge over which a person could fall
- on or in the vicinity of a surface through which a person could fall
- on or near the vicinity of a slippery, sloping or unstable surface.

Risk control means taking action to eliminate health and safety risks so far as is reasonably practicable, and if that is not possible, minimising the risks so far as is reasonably practicable. Eliminating a hazard will also eliminate any risks associated with that hazard.

Competent person means a person who has acquired through training, qualification or experience the knowledge and skills to carry out the task.

Further definitions relating to fall control measures are listed in Appendix A.

1.3 What is required to manage the risk of falls?

Regulation 34–38

In order to manage risk under the WHS Regulations, a duty holder must:

- *identify reasonably foreseeable hazards that could give rise to the risk*
- *eliminate the risk so far as is reasonably practicable*
- *if it is not reasonably practicable to eliminate the risk – minimise the risk so far as is reasonably practicable by implementing control measures in accordance with the hierarchy of control*
- *maintain the implemented control measure so that it remains effective*
- *review, and if necessary revise, risk control measures so as to maintain, so far as is reasonably practicable, a work environment that is without risks to health and safety.*

This Code provides guidance on how to manage the risks of persons falling from one level to another by following a systematic process that involves:

- identifying hazards that may cause injury
- if necessary, assessing the risks associated with these hazards
- implementing risk control measures
- reviewing risk control measures to ensure they are effective.

Guidance on the general risk management process is available in the *Code of Practice: How to Manage Work Health and Safety Risks*.

Consulting workers

Consultation involves sharing of information, giving workers a reasonable opportunity to express views and taking those views into account before making decisions on health and safety matters.

Section 47

The WHS Act requires that you consult, so far as is reasonably practicable, with workers who carry out work for you who are (or are likely to be) directly affected by a work health and safety matter.

Section 48

If the workers are represented by a health and safety representative, the consultation must involve that representative.

You must consult your workers and their health and safety representatives at every step of the risk management process. By drawing on their experience, knowledge and ideas, you are more likely to identify fall hazards and develop effective control measures.

Consulting, co-operating and co-ordinating activities with other duty holders

Section 46

The WHS Act requires that you consult, co-operate and co-ordinate activities with all other persons who have a work health or safety duty in relation to the same matter, so far as is reasonably practicable.

Sometimes you may share responsibility for a health and safety matter with other business operators who are involved in the same activities or who share the same workplace. In these situations, you should find out who is doing what and work together with other duty holders in a co-operative and co-ordinated way so that all risks are eliminated or minimised, so far as is reasonably practicable.

For example, the owner of a transport company with large trucks should consult the goods suppliers as well as the businesses having the goods delivered about how the risk of falls will be controlled during loading and unloading. This may include checking whether suitable equipment is available at each site so that workers do not have to climb on top of loads on the truck and be at risk of falling.

Further guidance is available in the *Code of Practice: Work Health and Safety Consultation, Co-operation and Co-ordination*.

2. Managing the risk of falls

2.1 How to identify fall hazards

You must identify all locations and tasks that could cause injury due to a fall. This includes access to the areas where work is to be carried out. Tasks that need particular attention are those carried out:

- on any structure or plant being constructed or installed, demolished or dismantled, inspected, tested, repaired or cleaned
- on a fragile surface (for example, cement sheeting roofs, rusty metal roofs, fibreglass sheeting roofs and skylights)
- on a potentially unstable surface (for example, areas where there is potential for ground collapse)
- using equipment to work at the elevated level (for example, when using elevating work platforms or portable ladders)
- on a sloping or slippery surface where it is difficult for people to maintain their balance (for example, on glazed tiles)
- near an unprotected open edge (for example, near incomplete stairwells)
- near a hole, shaft or pit into which a worker could fall (for example, trenches, lift shafts or service pits).

Inspect the workplace

Walk around the workplace and talk to your workers to find out where work is carried out that could result in falls. A checklist may be useful in this process. Key things to look for include:

- surfaces:
 - the stability, fragility or brittleness
 - the potential to slip, for example where surfaces are wet, polished or glazed
 - the safe movement of workers where surfaces change
 - the strength or capability to support loads
 - the slope of work surfaces, for example, where they exceed 7 degrees.
- levels – where levels change and workers may be exposed to a fall from one level to another
- structures – the stability of temporary or permanent structures
- the ground – the evenness and stability of the ground for safe support of scaffolding or a work platform
- the working area – whether it is crowded or cluttered
- entry and exit from the working area
- edges – protection for open edges of floors, working platforms, walkways, walls or roofs
- holes, openings or excavations – which will require guarding
- hand grip – places where hand grip may be lost.

In some situations, advice may be needed from technical specialists, such as structural engineers, to check the stability of structures or load bearing capacity.

Review available information, including incident records

You should check your records of previous injuries and 'near miss' incidents related to falls.

Information and advice about fall hazards and risks relevant to particular industries and work activities is also available from regulators, industry associations, unions, technical specialists and safety consultants.

2.2 How to assess the risk

A risk assessment will help you determine:

- what could happen if a fall did occur and how likely it is to happen
- how severe a risk is
- whether any existing control measures are effective
- what action you should take to control the risk
- how urgently the action needs to be taken.

A risk assessment is unnecessary if you already know the risk and how to control it.

When assessing the risks arising from each fall hazard, the following matters should be considered:

- the design and layout of elevated work areas, including the distance of a potential fall
- the number and movement of all people at the workplace
- the proximity of workers to unsafe areas where loads are placed on elevated working areas (for example, loading docks) and where work is to be carried out above people and there is a risk of falling objects
- the adequacy of inspection and maintenance of plant and equipment (for example, scaffolding)
- the adequacy of lighting for clear vision
- weather conditions – the presence of rain, wind, extreme heat or cold can cause slippery or unstable conditions
- the suitability of footwear and clothing for the conditions
- the suitability and condition of ladders, including where and how they are being used
- the adequacy of current knowledge and training to perform the task safely (for example, young, new or inexperienced workers may be unfamiliar with a task)
- the adequacy of procedures for all potential emergency situations.

Generic risk assessment

If you are responsible for a number of different work areas or workplaces and the fall hazards are the same, you may perform a single (or generic) risk assessment. However, you should carry out a risk assessment on individual fall hazards if there is any likelihood that a person may be exposed to greater, additional or different risks.

2.3 How to control the risk

There are a number of ways to control the risks of falls. Some control measures are more effective than others. Control measures can be ranked from the highest level of protection and reliability to the lowest. This ranking is known as the hierarchy of control. The WHS Regulations require duty holders to work through this hierarchy to choose the control that most effectively eliminates or minimises the risk in the circumstances. This may involve a single control measure or a combination of two or more different controls.

In managing the risks of falls, the WHS Regulations require the following specific control measures to be implemented, where it is reasonably practicable to do so:

1. Can the need to work at height be avoided to eliminate the risk of a fall?

- Carry out any work that involves the risk of a fall on the ground

2. Can the fall be prevented by working on solid construction?

- A building or structure that is used as an existing place of work and includes safe access and egress from which there is no risk of a fall from one level to another, for example properly constructed stairs with fixed handrails, flat roofs with a parapet or permanently installed guard rails around the edges.

It is usually not necessary to implement additional control measures to manage the risk of falls for workplaces in buildings that already comply with the requirements of the National Construction Code of Australia, for example in relation to stairs, mezzanines and balconies.

3. Can the risk of a fall be minimised by providing and maintaining a safe system of work, including:

- providing a fall prevention device (for example, installing guard rails) if it is reasonably practicable to do so, or
- providing a work positioning system (for example, an industrial rope access system) if it is not reasonably practicable to provide a fall prevention device, or
- providing a fall-arrest system, so far as is reasonably practicable, if it is not reasonably practicable to provide a fall prevention device or a work positioning system.

In some cases a combination of control measures may be necessary, for example using a safety harness while working from an elevating work platform.

Control measures are needed where there is a risk of injury irrespective of fall height. For low falls, you should assess the risk and provide reasonably practicable measures that reflect the risk. For example, there may be a risk of injury to workers standing on a narrow 1.7 metre high platform next to a production line where they have to work with their back to the open edge or where there is a risk of falling onto an uneven surface with sharp edges or protrusions. In this situation it may be reasonably practicable to install a guard rail along the edge of the platform.

Sometimes it may not be reasonably practicable to provide guard rails, for example at the edges of railway platforms or vehicle inspection pits. Other safe systems of work to provide adequate protection should be implemented, for example brightly painted lines to designate edges.

Work of long duration and higher frequency will usually require control measures higher up the hierarchy to provide adequate protection, for example using a mobile scaffold instead of a ladder.

You should also ensure that the control measures you select do not create new hazards, for example electrical risks from contact with overhead power lines or crushing and entanglement from plant such as elevating work platforms.

Implementing and maintaining control measures

Regulation 37

You must ensure that the control measures you implement remain effective. This includes checking that the control measures are fit for purpose; suitable for the nature and duration of the work; are installed and used correctly.

To allow the chosen control measures to operate effectively, you should:

- **develop work procedures** on how to correctly install, use and maintain the control measure.
The procedures should include a planned program of inspections and maintenance for the control measures. The inspection regime should include details of:
 - the equipment to be inspected (including its unique identification)
 - the frequency and type of inspection (pre-use checks, detailed inspections)

- action to be taken on finding defective equipment
- means of recording the inspections
- training of users
- the system of monitoring the inspection regime to verify that inspections are carried out appropriately.
- The manufacturer and/or supplier of the equipment should be consulted for any product specific requirements. If any signs of wear or weakness are found during the inspection, the components or means of attachment must be withdrawn from use until they are replaced with properly functioning components.
- **provide information, training and instruction** to workers, including procedures for emergency and rescue. You should also cover:
 - the type of control measures used to prevent falls
 - procedures for reporting fall hazards and incidents
 - the correct selection, fitting, use, care, inspection, maintenance and storage of fall-arrest and restraint equipment
 - the correct use of tools and equipment used in the work (for example, using a tool belt instead of carrying tools)
 - control measures for other potential hazards (for example, electrical hazards).
- **provide supervision** by ensuring that workers exposed to a risk of a fall are adequately supervised by a competent person, especially if they are undergoing training or are unfamiliar with the working environment. Check that:
 - only workers who have received training and instruction in relation to the system of work are authorised to carry out the work
 - workers use the fall control measure in the correct manner.

2.4 How to review control measures

The control measures that are put in place to prevent falls must be reviewed, and if necessary revised, to make sure they work as planned and to maintain an environment that is without risks to health and safety.

Regulation 38

A person conducting a business or undertaking must review and as necessary revise fall control measures:

- *when the control measure does not control the risk so far as is reasonably practicable*
- *before a change at the workplace that is likely to give rise to a new or different health and safety risk that the control measure may not effectively control*
- *if a new hazard or risk is identified*
- *if the results of consultation indicate that a review is necessary*
- *if a health and safety representative requests a review.*

Control measures may be reviewed using the same methods as the initial hazard identification step.

Consult your workers and their health and safety representatives and consider the following:

- Are the control measures working effectively in both their design and operation?
- Are all fall hazards being identified?
- Are workers using the control measures in accordance with the instruction and training that has been provided?

3. Work on the ground or on a solid construction

3.1 Work on the ground

Eliminating the need to work at height is the most effective way of protecting workers from the risk of falls. Examples of eliminating the risk by working on the ground include:

- prefabricating roofs at ground level
- prefabricating wall frames horizontally, then standing them up
- using mechanical tarp spreaders to cover loads on trucks from the ground
- fitting outlets, inlets and controls of large tanks and silos near the ground (see Figure 1)
- reducing shelving heights so that workers can access items from ground level
- using tools with extendable handles, such as paint rollers (the risk of musculoskeletal disorders will need to be considered when deciding whether to use such tools)
- installing windows that pivot to enable cleaning from a safe position inside a building
- lowering a concert hall chandelier to repair it.

Figure 1

A silo showing sight glass and ground delivery tube

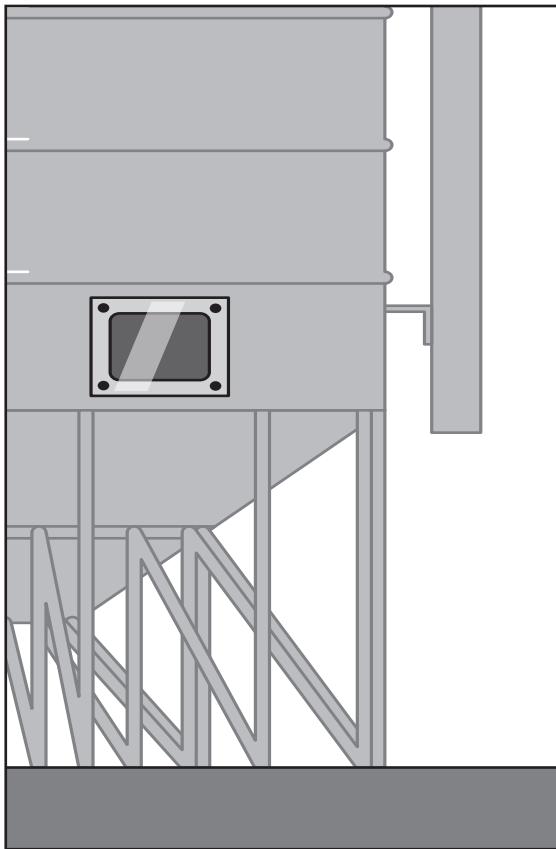

3.2 Work on a solid construction

Working on a solid construction provides an environment where the likelihood of a fall may be eliminated. 'Solid construction' means an area that:

- is structurally capable of supporting workers, material and any other loads applied to it
- is provided with barriers around its perimeter and around any openings from or through which a person could fall
- has an even, accessible surface and gradient
- has a safe means of entry and exit.

Structural strength

Different types of work involve different loads on the supporting surface. The surface and its supports must be able to safely carry the expected loads, including workers, materials, tools and equipment. When in doubt, have a structural engineer determine the safe load capacity before use.

Barriers

Barriers (or edge protection) to prevent a person falling over edges and into holes should be provided on relevant parts of a solid construction. These include:

- the perimeters of buildings or other structures
- mezzanine floors (see Figure 2)
- openings in floors
- the open edge of a stair, landing, platform or shaft opening (see Figure 3).

Figure 2

A barrier on a mezzanine floor

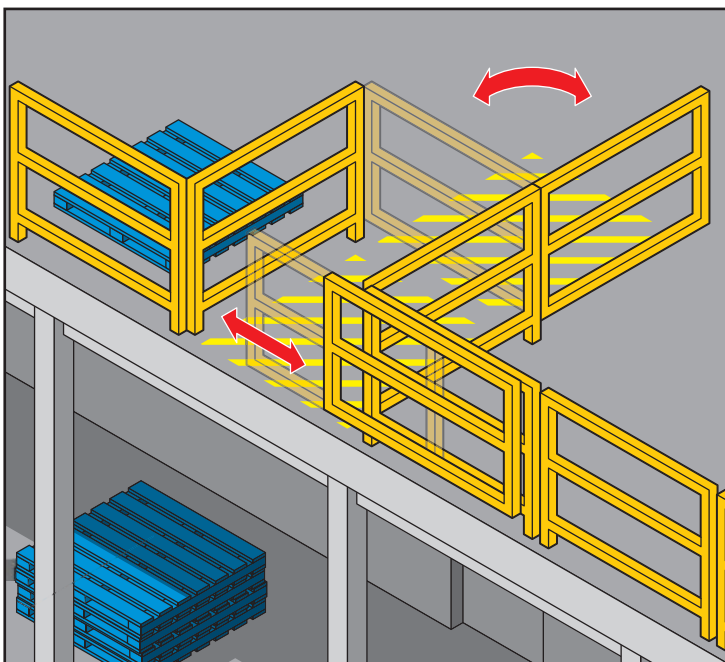
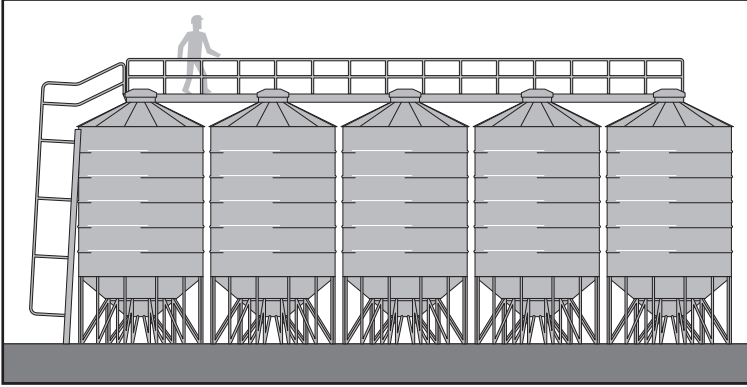

Figure 3

A platform with guard rails installed above silos



The barrier should be designed and constructed to withstand the force of someone falling against it.

Edge protection should consist of guard rails, solid balustrades or other structural components, for example wire mesh supported by posts and provided with a reinforced top edge. The top of the guard rail or component should be between 900 mm and 1,100 mm above the working surface. If a guard rail system is used, it should also have mid-rails and toe boards or wire mesh infill panels.

If access is required to equipment (for example, a hoist) it should be protected with gates, safety chains or other means to prevent a person falling.

Protection of openings and holes

Holes, penetrations and openings through which a person could fall should be made safe immediately after being formed.

If a cover is used as a control measure, it must be made of a material that is strong enough to prevent persons or objects falling through and must be securely fixed to prevent any dislodgement or accidental removal.

Figure 4

4 mm mesh embedded in the concrete floor. The hole should also be covered to prevent things falling through.

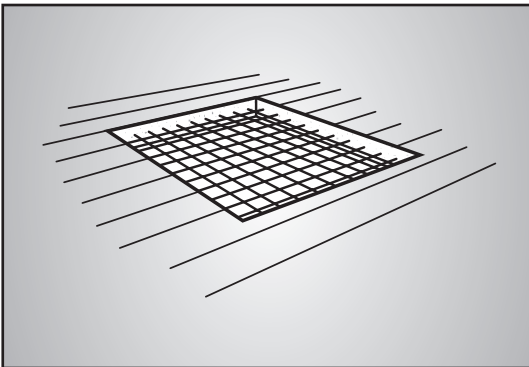
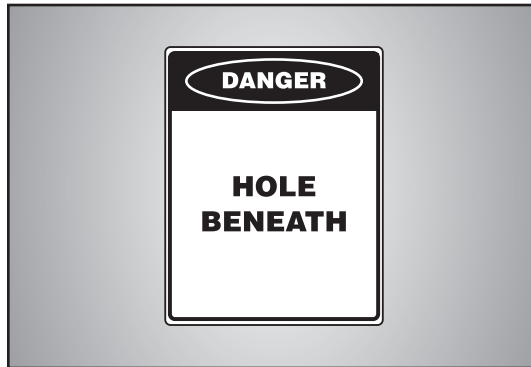

Figure 5

Example of the type of danger sign to be affixed to the hole cover.



Surface and gradient

Surfaces of solid construction should be non-slip, free from trip hazards and should generally not exceed 7 degrees (1 in 8 gradient). Cleated surfaces, which provide greater slip-resistance, should not be steeper than 20 degrees (1 in 3 gradient).

If grid mesh or checker plate flooring is used for walkways and working platforms, ensure that:

- flooring panels are securely fixed and assembled in accordance with manufacturer's specifications
- where possible, they are fitted to the structure prior to it being lifted into permanent position
- each panel is fixed securely before the next panel is placed in position
- during installation, this type of flooring is secured by tack welding, panel grips or other means to prevent movement before being fixed permanently
- if panels of grid mesh or checker plate flooring are removed, edge protection is provided and the gaps left due to removed panels are protected.

Entry and exit

The solid construction must have a safe means for people to get to, from and move around the work area, for example permanently installed platforms, ramps, stairways and fixed ladders.

Further guidance is available in AS 1657 *Fixed platforms, walkways, stairways and ladders – Design, construction and installation*.

Safety considerations include:

- exposure of access systems to the weather (for example, rain can make surfaces slippery and strong winds can cause loss of hand grip)
- the provision of adequate natural or artificial lighting to all access ways
- the clearance of obstructions so that persons are able to move easily to and from the workplace.

Portable ladders should only be used where the use of safer systems is not reasonably practicable.

4. Fall prevention devices

A fall prevention device is any equipment that is designed to prevent a fall for temporary work at heights, and once in place does not require any further adjustment by workers using the device.

4.1 Temporary work platforms

A 'temporary work platform' is a working platform, other than a permanently installed fixed platform, used to provide a working area for the duration of the job. The design of the platform prevents workers from falling. Temporary work platforms include scaffolds, elevating work platforms, mast climbers, workboxes, building maintenance units, portable or mobile fabricated platforms or any other platform that provides a working area and is designed to prevent a fall.

Scaffolding

Scaffolding can be very effective protection in preventing falls; however, there are specific requirements that apply to some types of scaffold under the WHS Regulations.

Regulation 225

A person with management or control of a scaffold must not allow the use of a scaffold from which a person or object could fall more than four metres unless a competent person provides written confirmation that the scaffold has been completed. The person must also ensure that:

- *the scaffold and its supporting structure is inspected by a competent person before use, after any incident that could affect its stability (such as a severe storm), after any repairs, and at least every 30 days*
- *unauthorised access is prevented on scaffolding that is incomplete and left unattended (for example, by attaching danger tags and warning signs at appropriate locations).*

Scaffolding work platforms are generally rated as light, medium or heavy duty. Safety considerations include:

- scaffolding conforms to AS/NZS 4576 *Guidelines for scaffolding* and the AS/NZS 1576 *Scaffolding* series
- all scaffolding is erected, altered and dismantled by competent persons. Any scaffold from which a person or object could fall more than four metres must be erected, altered and dismantled by or under the direct supervision of a licensed scaffolder.
- prefabricated scaffolds are of the same type and not mixed components, unless the mixing of components has been approved by the manufacturer
- safe access to and egress from the scaffold is provided
- edge protection (hand rails, mid-rails and toe boards) is provided at every open edge of a work platform (see Figure 5).

Information, instruction and training for workers using scaffolds

Where work is performed from a scaffold, you must ensure that the relevant workers understand:

- what loads the scaffold can safely take
- not to make any unauthorised alterations to the scaffold (such as removing guard rails, planks, ties, toe boards and braces)
- that working platforms need to be kept clear of debris and obstructions along their length, and
- that incomplete or defective scaffolds must never be accessed.

Where work is performed using mobile scaffolds, workers should be trained to ensure the scaffold:

- remains level and plumb at all times
- is kept well clear of powerlines, open floor edges and penetrations
- is not accessed until the castors are locked to prevent movement
- is never moved while anyone is on it
- is only accessed using internal ladders (see Figure 7).

Figure 6

Perimeter scaffold with a fully decked working platform, guardrails and toeboards.

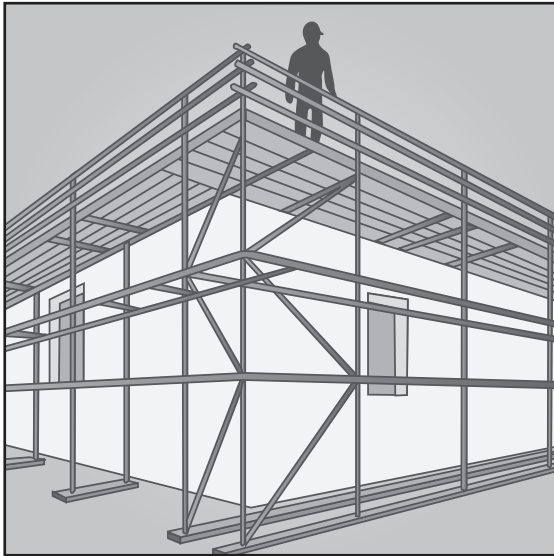
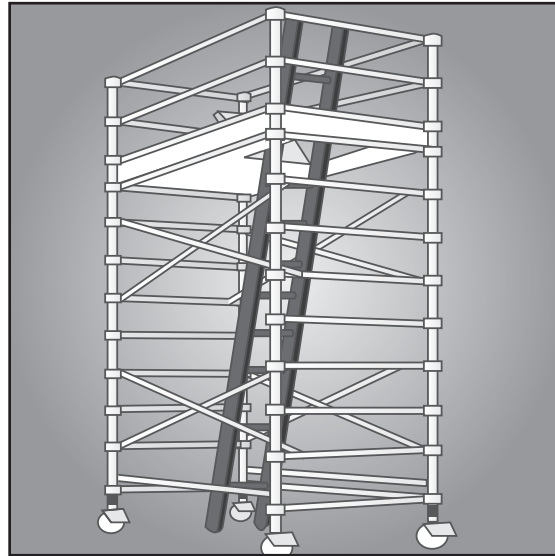

Figure 7

Mobile scaffold with an access ladder and trapdoor to provide the largest possible hazard-free working platform.



Light duty suspended scaffold

A suspended scaffold incorporates a suspended platform that is capable of being raised or lowered when in use (see Figure 8). Common types of suspended scaffolds include:

- swing stages which have cradles supported by a single row of suspension ropes
- double rope scaffolds, with cradles supported by two rows of suspension ropes
- work cages which are small cradles supported by one suspension rope only
- false cars, which are specialised forms of suspended scaffolding and are often used in the construction of lifts before lift cars are installed.

There are specific safety considerations for swing stages, including that:

- the working load and specifications are in accordance with AS 1576.4 *Scaffolding – Suspended Scaffolding*
- persons operating light duty suspended stages are trained in safe operation
- persons installing or servicing a light duty suspended stage hold a licence for advanced rigging or advanced scaffolding
- where the swing stage is suspended by two wire ropes to each winch, a safety harness and restraint lanyard is attached to a suitable anchor point of the swing stage.

Further guidance on the safe design, erection and use of scaffolding, including suspended scaffolding, is available in the *Scaffolding Code of Practice [under development]*.

Figure 8

Example of a light duty suspended scaffold with two wire ropes to each winch. The platform must remain horizontal when moving it up or down.

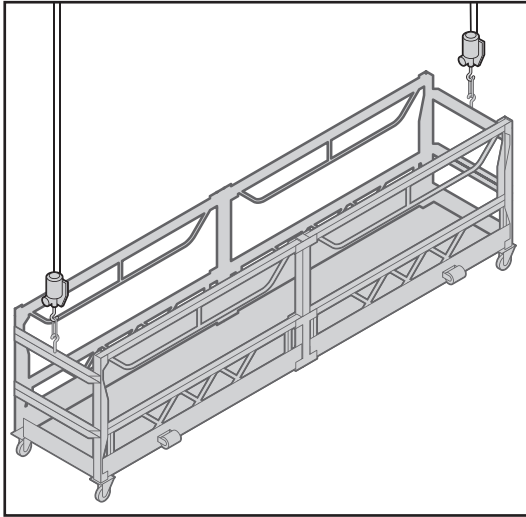

Elevating work platforms

Elevating Work Platforms (EWPs) include scissor lifts, cherry pickers, boom lifts and travel towers. There are battery powered and internal combustion engine types. Some are designed for hard flat surfaces only, while others are designed to be operated on rough terrain.

Safety considerations include that:

- workers operating the platform are trained and instructed in safe operating procedures for the particular brand and type of equipment, as well as the safe use of fall-arrest equipment and emergency rescue procedures
- the platforms are only used as working platforms and not as a means of entering and exiting a work area unless the conditions set out in AS 2550.10 *Cranes, hoists and winches – Safe use – Mobile elevating work platforms* are met
- unless designed for rough terrain, the platforms are used only on a solid level surface
- the surface area is checked to make sure that there are no penetrations or obstructions that could cause uncontrolled movement or overturning of the platform
- the manufacturer's or supplier's instructions are consulted for information on safe operation
- persons working in travel towers, boom lifts or cherry pickers wear a properly anchored safety harness
- workers are licensed when operating boom-type elevating work platforms with a boom length of 11 metres or more.

Figure 9

An example of a boom-type elevating work platform. The safety harness and lanyard assembly are not shown for purposes of clarity. The lanyard should be as short as possible and should be attached directly to the designated anchor point on the EWP, not to the handrail.

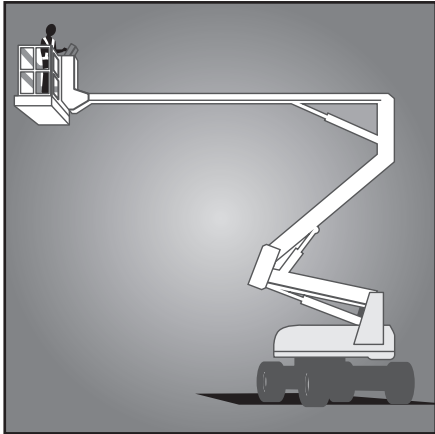
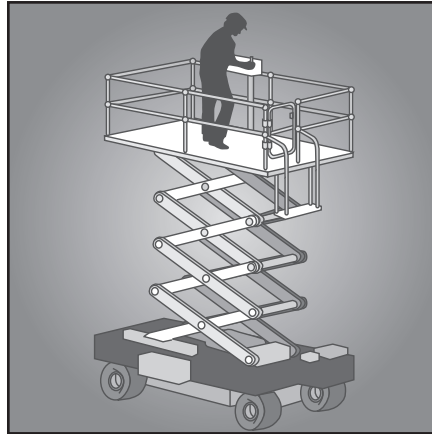

Figure 10

An example of a scissor-lift elevating work platform.



Mast climbing work platforms

Mast climbing work platforms are hoists with a working platform that is used to raise workers and material to a temporary working position. They use a drive system mounted on an extendable mast, which may need to be tied to a building under circumstances prescribed by the manufacturer.

Mast climbing work platforms can be set up in either single-mast or multi-mast configurations. They are generally not suitable for use if the profile of a structure changes at different elevations (for example, if the upper floors of a building 'step' back or balconies protrude from the building).

The erection and dismantling of mast climbing work platforms must be carried out, or be directly supervised, by a person holding an appropriate rigging or scaffolding licence.

Further information on mast climbing work platforms is provided in AS 2550.16 *Cranes – Safe Use – Mast climbing work platforms*.

Figure 11

An example of a typical mast climbing work platform.

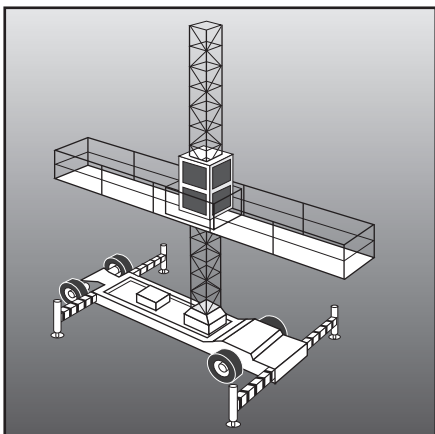

Workboxes

A workbox is designed to be supported by a crane, hoist, forklift truck or other mechanical device to provide an elevated work area for persons working from the box. It consists of a platform surrounded by an edge protection system and should be designed in accordance with AS 1418.17 *Cranes (including hoists and winches) – Design and construction of workboxes*.

Where reasonably practicable, other working platforms, such as an elevating working platform or scaffold, should be used as an alternative to the workbox.

The safety requirements and considerations include that:

- the workbox is not suspended over persons
- the workbox is designed for the task and securely attached to the crane. The workbox, lifting attachments and records should be checked by a competent person before use
- the workbox is fitted with a suitable anchorage capable of withstanding the fall forces specified in AS/NZS 1891.4 *Industrial fall-arrest systems and devices – Selection, use and maintenance*. Workers must be attached to the anchorage by a lanyard and harness unless the workbox is fully enclosed
- workers remain within the workbox while they are being lifted or suspended
- workers do not enter or leave the workbox when it is suspended (except in an emergency)
- the crane is fitted with the means to safely lower it in an emergency or a power supply failure
- the crane is suitably stabilised at all times while the workbox is used
- the crane has 'drive up' and 'drive-down' controls on both the hoisting and luffing motions and those controls are used. No declutching allowing free fall is to be used while a workbox is in use
- an effective means of communication between any person in the workbox and the operator is provided
- the crane is fitted with a safety hook and moused (lashed) accordingly
- the operator remains at the controls of the crane at all times.

For specifications for the use of crane workboxes refer to AS 2550.1 *Cranes, Hoists and Winches – Safe Use – General Requirements*.

Forklifts with a work box

A workbox fitted to a forklift must be securely attached to the forklift carriage and engineer-designed and constructed in accordance with AS 2359 *Powered Industrial Trucks* (see Figure 12).

Safety considerations include that:

- people are not raised on the tynes of forklift trucks or the pallet
- no other device (for example, ladder or pallets) is used to gain additional height (see Figures 13 and 14)
- the safety gate is self-locking and kept shut when in the elevated position.

Figure 12

An example of an engineer-designed workbox with safety harness and lanyard assembly, correctly positioned on the forklift tynes.

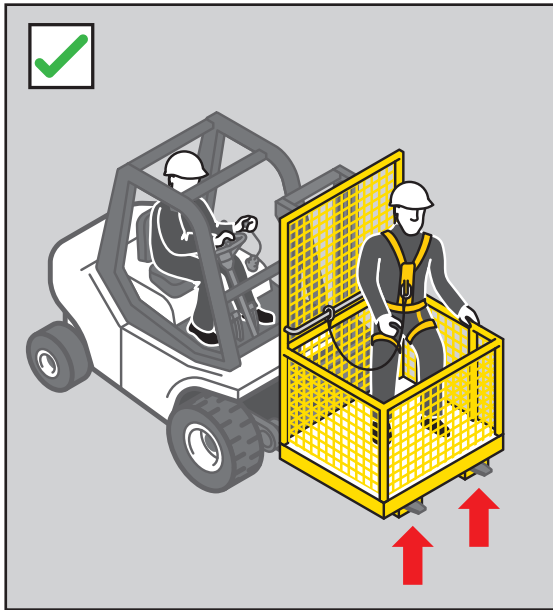

Figure 13

Using a forklift as a working platform or to gain extra height by standing on the tynes or a pallet is an unacceptable practice.

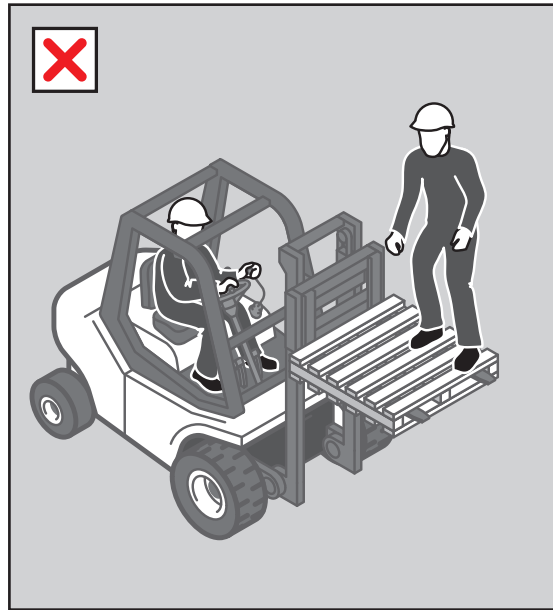
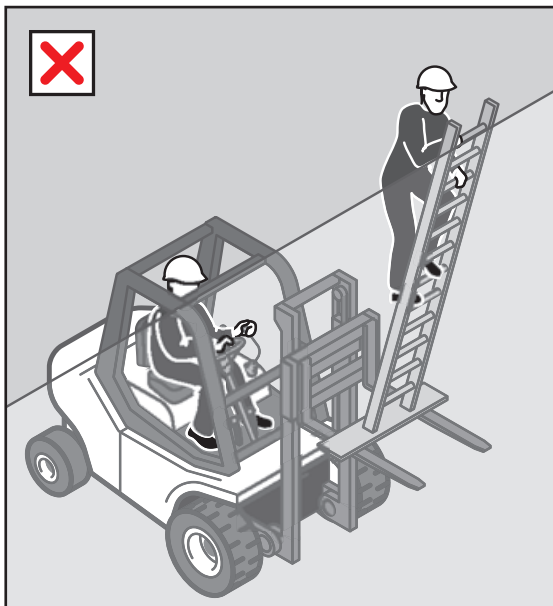

Figure 14

Unacceptable practice with ladder on forklift.



Building maintenance units

Designers of buildings should consider the methods by which maintenance, repairs or cleaning will be undertaken on buildings or structures.

A building maintenance unit is a power-operated suspended working platform that is fixed permanently to a building or structure. It is used for access for building maintenance or window cleaning (see Figure 15).

Safety considerations include that:

- the platform has sufficient, clearly designated safety harness anchorage points designed to withstand the forces caused by a fall of any person located anywhere on the platform
- the units are designed in accordance with AS 1418.13 *Cranes (including Hoists and Winches) – Building Maintenance Units* and operated by competent persons in accordance with AS 2550.13 *Cranes – Safe Use – Building Maintenance Units*.

Platforms supported by trestle ladders

Trestle ladder scaffolds are only suitable for use at heights greater than two metres when guard rails and toe boards are incorporated to prevent people and material falling off the working platform. The system (including planks) should be assembled according to the manufacturer’s specifications with the complete set of compatible components.

Some trestle ladder scaffolds include outriggers to increase stability (see Figure 16). Trestle ladder scaffolds are only suited to light duty tasks such as painting and rendering. Work should only be performed between the trestles. The minimum width of the working platform should not be less than 450 mm.

Alternatives to trestle ladders should be considered, such as small scissor lifts, light duty aluminium mobile scaffolds, boom arms and modular scaffolding.

Figure 15

An example of a building maintenance unit with safety harness and restraint line.



Figure 16

Trestle ladder scaffold with guard rails and outriggers for stability.

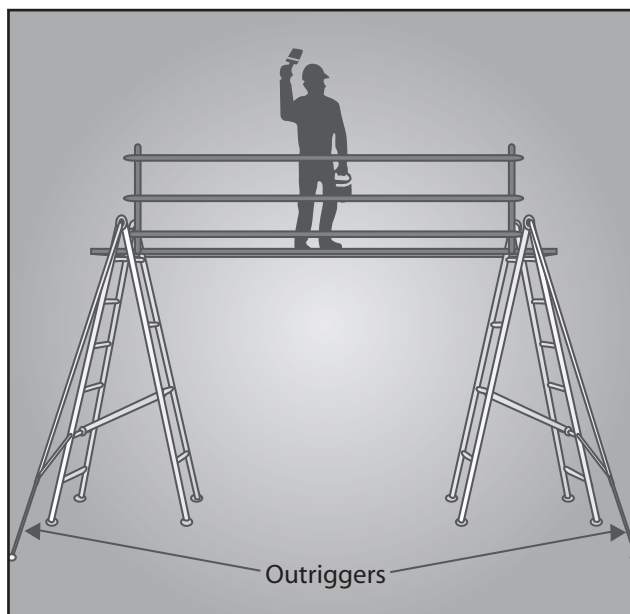

4.2 Perimeter guard rails

Guard rails may be used to provide effective fall prevention:

- at the edges of roofs
- at the edges of mezzanine floors, walkways, stairways, ramps and landings
- on top of plant and structures where access is required (see Figure 17)
- around openings in floor and roof structures
- at the edges of shafts, pits and other excavations.

Guard rails should incorporate a top rail 900 mm to 1,100 mm above the working surface and a mid rail and a toe board.

Before using a guard rail system you should check that it will be adequate for the potential loads. The required load resistance will depend on the momentum of a falling person. For example, the momentum of a person falling from a pitched roof will increase as the pitch (or angle) of the roof increases.

Refer to AS/NZS 4994 – *Temporary Edge Protection* series for further guidance.

Figure 17

Guard rails installed on top of a tanker to enable safe access to tank hatches.

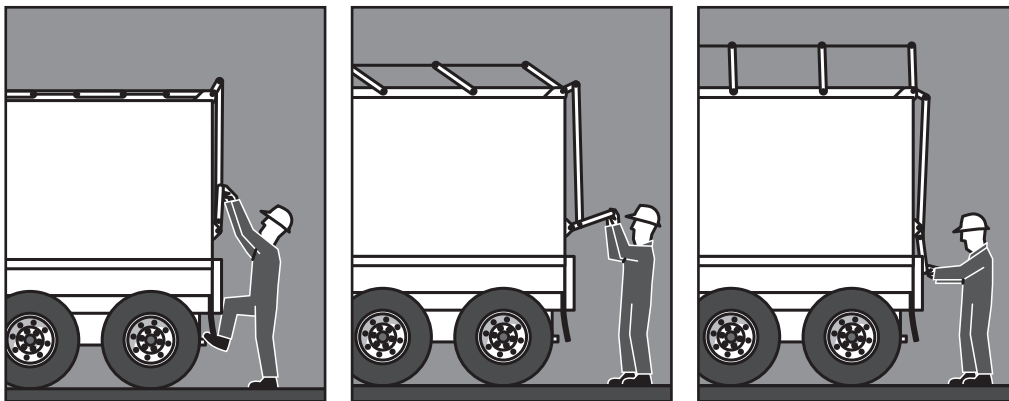

4.3 Safety mesh

Safety mesh is designed to prevent internal falls through a roof. If securely fixed, safety mesh provides fall protection for roof installers and offers long-term protection against falling for maintenance and repair workers.

Safety mesh does not prevent falls from the edge of a roof or through holes in a roof, so it should always be used in conjunction with appropriate edge protection, guard rails or fall-arrest systems.

Safety mesh should comply with AS/NZS 4389 *Safety mesh*, which specifies the minimum requirements for the design, construction, testing and installation of safety mesh for use in domestic, commercial and industrial building applications.

The mesh should be formed from 2 mm diameter wire of not less than 450 MPa tensile strength, welded into a mesh with the longitudinal wires not more than 150 mm apart and the cross wires not more than 300 mm apart.

Safety mesh should be installed in accordance with the manufacturer's instructions by competent persons, who should be protected against the risk of falling by using appropriate control measures such as scaffolding, elevating work platforms or fall-arrest systems.

Particular care is required to ensure that the mesh is securely connected to the structure and the overlap between adjacent sections of mesh is sufficient to generate the necessary strength to resist the force of a person falling onto it. The safety mesh should be covered by the roof cladding as soon as reasonably practicable after it has been installed.

5. Work positioning systems

A work positioning system involves the use of equipment that enables a person to work supported in a harness in tension in such a way that a fall is prevented.

Work positioning systems require a high level of competency on the part of the user and supervisors to ensure safe use. Users, including supervisors, should undertake a competency based course of training.

5.1 Industrial rope access systems

Industrial rope access systems are used for gaining access to and working at a workface, usually by means of vertically suspended ropes. Although fall-arrest components are used in the industrial rope access system, the main purpose of the system is to gain access to a work area rather than to provide backup fall protection (see Figure 18).

Other methods of accessing a workface should be considered (for example, EWPs or building maintenance units) before rope access systems, as a high level of skill is needed for their safe use.

You should ensure that, where it is necessary for industrial rope access systems to be used:

- operators are competent in the technique
- operators do not work alone, in case they require assistance in an emergency
- industrial rope access systems are installed only in a location where it is possible to provide prompt assistance or rescue if required (refer to Chapter 9 of this Code)
- all equipment is checked regularly by a competent person
- prior to use, all fixed anchorage points are checked by a competent person before attaching the rope access lines
- a back up system is used to protect the operator
- two independently anchored ropes are used for each person
- any person within three metres of an unguarded edge is adequately secured
- all operators wear a full body harness
- supervisors can communicate with workers
- where necessary, appropriate personal protective equipment is used, such as helmets, gloves, hearing protection, goggles and masks
- barricades and signposts are placed on all access areas below the working area and anchorage locations to exclude and alert the public and tradespeople.

Further guidance on industrial rope access systems is available in *AS/NZS 4488 Industrial rope access systems series*.

Figure 18

Operator using an ascender in an industrial rope access system.

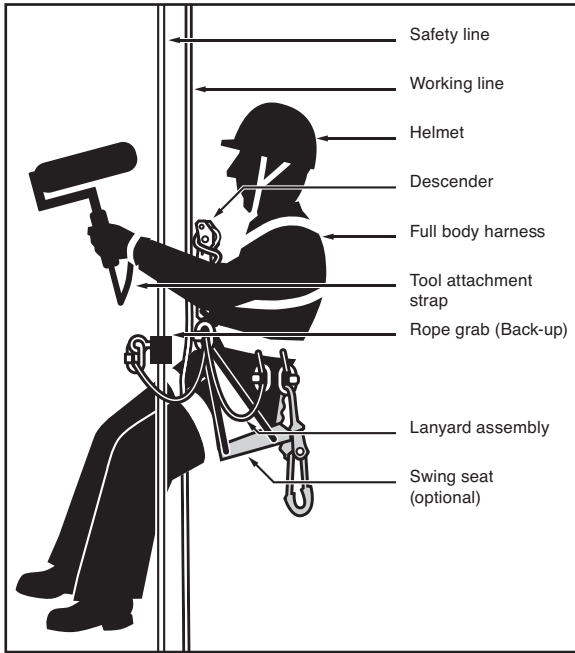

5.2 Restraint technique

A restraint technique controls a person's movement by physically preventing the person reaching a position at which there is a risk of a fall. It consists of a harness that is connected by a lanyard to an anchorage or horizontal life line. It must be set up to prevent the wearer from reaching an unprotected edge (see Figure 19).

Figure 19

Restraint technique options.

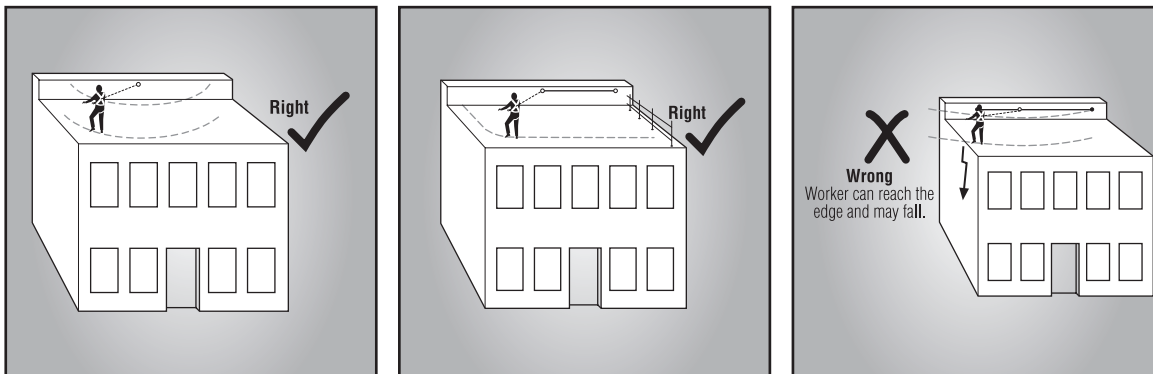

A restraint technique is suitable for use where:

- the user can maintain secure footing without having to tension the restraint line and without the aid of any other hand hold or lateral support. When deciding whether secure footing can be maintained, consider:
 - the slope of the surface
 - the supporting material type
 - the surface texture of the surface and whether it is likely to be wet, oily or otherwise slippery
- the horizontal life lines are fitted with an industrial shock absorber when required
- the restraint system conforms with AS/NZS 1891 *Industrial fall-arrest systems and devices* series.

Restraint techniques should only be used if it is not reasonably practicable to prevent falls by providing a physical barrier (for example, a guard rail). This is because restraint techniques require a high level of user skill to operate safely and also greater supervision.

A restraint system should be installed by a competent person in accordance with the manufacturer's instructions. Restraint anchorage should be designed for fall-arrest loading.

An individual fall-arrest system should be used instead of restraint techniques if any of the following situations apply:

- the user can reach a position where a fall is possible
- the user has a restraint line that can be adjusted in length so that a free fall position can be reached
- there is a danger the user may fall through the surface, for example fragile roofing material
- the slope is over 15 degrees

6. Fall-arrest systems

A fall-arrest system is intended to safely stop a worker falling an uncontrolled distance and reduce the impact of the fall. This system must only be used if it is not reasonably practicable to use higher level controls or if higher level controls might not be fully effective in preventing a fall on their own.

All equipment used for fall-arrest should be designed, manufactured, selected and used in compliance with the AS1891 series of standards.

Key safety considerations in using fall arrest systems are:

- the correct selection, installation and use of the equipment
- that the equipment and anchorages are designed, manufactured and installed to be capable of withstanding the force applied to them as a result of a person's fall
- that the system is designed and installed so that the person travels the shortest possible distance before having the fall stopped
- that workers using a fall-arrest system wear adequate head protection to protect them in the event of a fall
- that if the equipment has been used to arrest a fall it is not used again until it has been inspected and certified by a competent person as safe to use.

6.1 Catch platforms

A catch platform is a temporary platform located below a work area to catch a worker in the event of a fall. The platform should be of robust construction and designed to withstand the maximum potential impact load. Scaffolding components may be used to construct fixed and mobile catch platforms (see Figure 20).

Catch platforms should:

- incorporate a fully planked-out deck
- be positioned so the deck extends at least two metres beyond all unprotected edges of the work area, except where extended guard railing is fitted to the catch platform
- be positioned as close as possible to the underside of the work area – the distance a person could fall before landing on the catch platform should be no more than one metre
- always be used with an adequate form of edge protection.

Figure 20

An example of a catch platform below a work area.

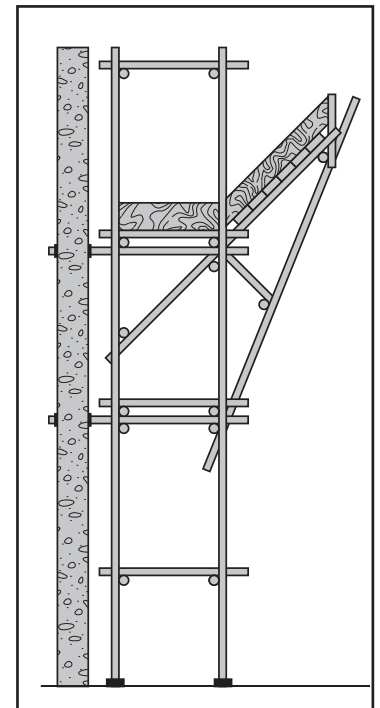

6.2 Industrial safety nets

Safety nets can provide a satisfactory means of protection while allowing workers maximum freedom of movement. They should not be used to enter or exit a work area or as a working platform.

If safety nets are used, you should ensure that:

- safety nets are securely anchored before any work starts
- safety nets are constructed of material strong enough to catch a falling person or thing
- safety nets are hung as close as is practicable to the underside of the working area, but no more than two metres below the working area
- perimeter safety nets used where there is no edge protection extend at least 2.5 metres beyond the leading edge of the working area
- the safety net has sufficient tension and clearance to prevent a falling person contacting any surface or structure below the net
- material is not allowed to accumulate in suspended safety nets
- no welding or oxy cutting is performed above safety nets
- safety nets are inspected, particularly after installation, relocation or repair
- safety nets are stored correctly in dry, shaded areas with good air circulation.

6.3 Individual fall-arrest systems

Individual fall-arrest systems consist of some or all of the following components:

- anchorages
- lifelines
- inertia reel
- lanyard of fixed length
- retractable lifelines
- rope grabs
- wire grabs
- rail system
- shock absorbers, both personal and industrial
- harness
- snap hooks (double or triple action to prevent rollout)
- karabiners (double or triple action to prevent rollout)
- rescue equipment.

Individual fall-arrest systems rely on workers wearing and using them correctly, and therefore workers who will use such a system must be trained in its safe use. They should only be used where it is not reasonably practicable to use higher level control measures.

Relevant Australian/New Zealand Standards for personal fall-arrest equipment require that they be permanently marked or labelled to indicate their purpose, correct use, limitations and other relevant information aimed at reducing misuse of the equipment.

Anchorage points

Each anchorage point should comply with the requirements in AS/NZS 1891:4 *Industrial fall-arrest systems and devices – selection, use and maintenance*.

All anchorages should be tested and approved by a competent person before use – a visual inspection may not reveal the structural integrity of the anchor point (ie the bolt may have failed below the concrete surface).

Each anchorage point should be located so that a lanyard of the system can be attached to it before the person using the system moves into a position where the person could fall.

Inspect the system components

Each component of the system and its attachment to an anchorage must be inspected by a competent person:

- after it is installed but before it is used
- at regular intervals
- immediately after it has been used to arrest a fall.

Inspection of all components should be conducted in accordance with the manufacturer's specifications and the relevant standards. If any signs of wear or weakness are found during the inspection, the components or means of attachment should be withdrawn from use until they are replaced with properly functioning components.

Limit free fall distance

Fall-arrest systems, incorporating a lanyard, should be installed so that the maximum distance a person would free fall before the fall-arrest system takes effect is two metres. There should be sufficient distance between the work surface and any surface below to enable the system, including the action of any shock absorber to fully deploy (see Figure 21). To work out whether there is enough distance available, you should take into account:

- the worker's height
- the height and position of the anchorage point
- the length of the lanyard
- any slack in the horizontal life line
- any stretching of the lanyard or horizontal life line when extended by a fall
- the length of the energy absorber when extended by a fall.

Figure 21

Total fall distance before this particular configuration would be effective in arresting a fall is 6.5 m.

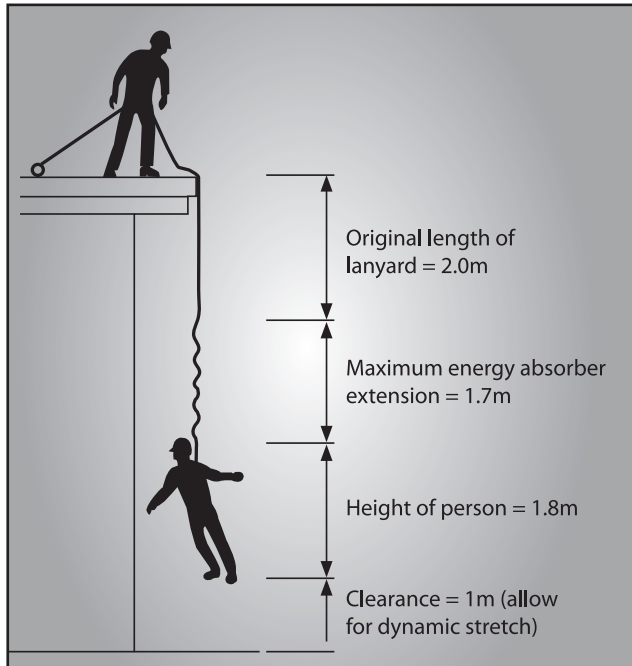

Lanyards should **not** be used in conjunction with inertia reels as this can result in an excessive amount of free fall prior to the fall being arrested.

Use suitable harnesses

In most cases, a full body harness should be worn. Harnesses must be correctly fitted. Workers should connect the fall-arrest line to the attachment point on their harness (dorsal attachment point or the chest connection) that will provide the best protection in the situation it is being used. Consideration should be given to the potential fall distance, potential impact with the structure, body position after a fall and the need to interact with equipment such as rope-grabs.

Maintain minimum of slack in fall-arrest lanyard

There should be a minimum of slack in the fall-arrest lanyard between the user and the attachment. The anchorage point should be as high as the equipment permits. Avoid work above the anchor point, as this will increase the free fall distance in the event of a fall, resulting in higher forces on the body and greater likelihood of the lanyard snagging on obstructions.

Use inertia reels correctly

When considering the use of inertia reels, bear in mind that they might not be effective in certain situations. For example, if a worker falls down the inclined surface of a steeply pitched roof, the inertia reel line may keep extending from the reel – it may not lock.

Inertia reels should not be used as working supports by locking the system and allowing it to support the user during normal work. They are not designed for continuous support.

Vertical and self-retracting anchorage lines can be used as a risk control measure in connection with work performed from boatswains' chairs and ladders. Where such lines are used, only one person may be attached to any one line.

Use compatible components

The use of non-compatible components may lead to 'roll-out' with some hook/karabiner configurations, resulting in injury or death to the user. The hazard cannot always be avoided by using components produced by the same manufacturer under the one brand name. If you are unsure whether components of a fall-arrest system are compatible you should contact the manufacturer for further information.

Snap hooks should be of the double action type, requiring at least two consecutive deliberate actions to open. Snap hooks should not be connected to each other as this could prevent the safe operation of the snap hook (for example, roll-out may occur). Some double action hooks are susceptible to roll-out. Screw gate karabiners or hex nut connectors may sometimes be appropriate. Further guidance is provided in AS/NZS 1891 *Industrial fall-arrest systems and devices*.

Figure 22

Roll-out on a small diameter eyebolt.

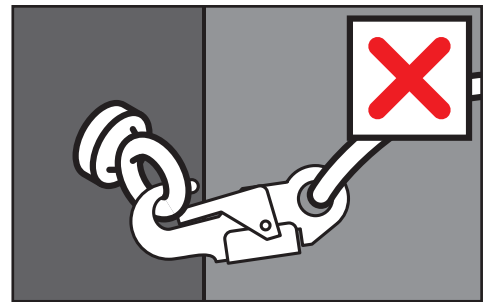

Ensure prompt rescue in event of fall

A person conducting a business or undertaking who implements a fall-arrest system as a control measure must establish emergency and rescue procedures. The rescue of a worker who is suspended in a full body harness must occur promptly to prevent suspension intolerance.

A worker should not use a fall-arrest system unless there is at least one other person on the site who can rescue them if they fall.

Hazards with individual fall-arrest systems

If a person using an individual fall-arrest system falls, the system may act as a pendulum, and in some situations the user may hit the ground (called 'swing down': see Figure 23) or swing back onto the building or structure (which is called 'swing back': see Figure 24).

Swing down can occur if the lanyard slides back along the perimeter edge of the roof until it is vertical. When this happens, the person may hit the ground, or the lanyard may break as a result of its contact with the edge of the roof. Measures to address 'swing down' include:

- the installation of guard rails
- placing the anchorage point at a right angle to the position of the lanyard at the perimeter edge (for example, by using a mobile anchorage)
- the installation of a second anchorage point and belay devices (intermediate anchorages).

Figure 23

During 'swing down' the length of the lanyard and positioning of the anchor allow contact with the ground.

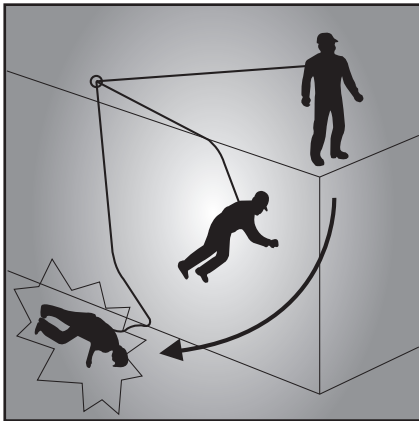
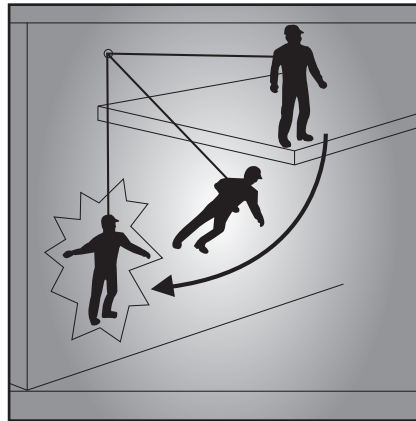

Figure 24

During 'swing back' the length of the lanyard and positioning of the anchor contact may allow the worker to hit the structure.



6.4 Anchorage lines or rails

Anchorage lines or rails are temporary or permanent fall-arrest systems, which can be installed to provide continuous fall protection for persons using ladders or climbing towers. These can be used on plant, such as tower cranes, as well as buildings or structures.

Safety considerations include that:

- temporary systems comply with the AS/NZS 1891 series of standards
- the locking device is attached to the frontal attachment point of the harness and the lanyard assembly is a maximum of 300 mm length
- the point of connection onto the ladder by the climber is near the base of the ladder to allow the connection before ascending begins and also to provide continuous connection to the disconnecting point when at a safe higher level
- free fall is limited to a maximum of 600 mm
- permanent systems are of wire or rail construction and are installed according to the manufacturer's instructions

After a fall, remove the system from service and have it inspected by a competent person before it is used again.

Figure 25

With the use of an anchorage line system, the person climbing has continuous fall protection by being attached to the anchorage line and harness.

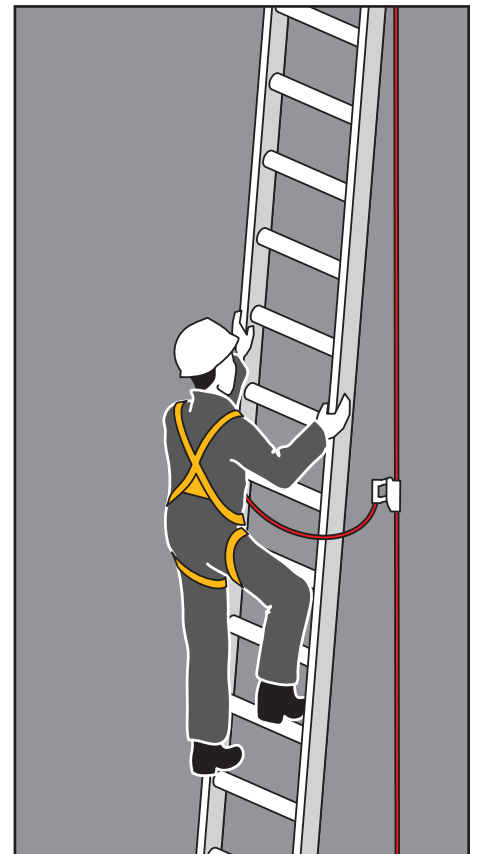

Double lanyards

An alternative to anchorage lines or rails is the use of a double lanyard (also known as a twin tail or 'Y' lanyard). Figure 26 shows how the use of a double lanyard means that the person climbing can always be connected to the ladder or structure.

However, double lanyards are easy to misuse – there should be no back hooking, they should not be wrapped around the body or passed between the legs, the chest connection should never be higher than the highest attachment point, they are not suitable for frequent use (because of possible misuse or muscle injury) and the ladder or structure points must be capable of arresting forces generated by a fall with the double lanyard. Adequate training should be provided on their use.

Figure 26

Left: An example of a double lanyard. These must have double action connectors.

Right: Person climbing with a double lanyard. Note that in this application the connectors will slide down to the lowest point on the rail and likely be subject to side loading. Side loading can be controlled by using soft connections such as slings or the use of hooks rated to withstand side loading.

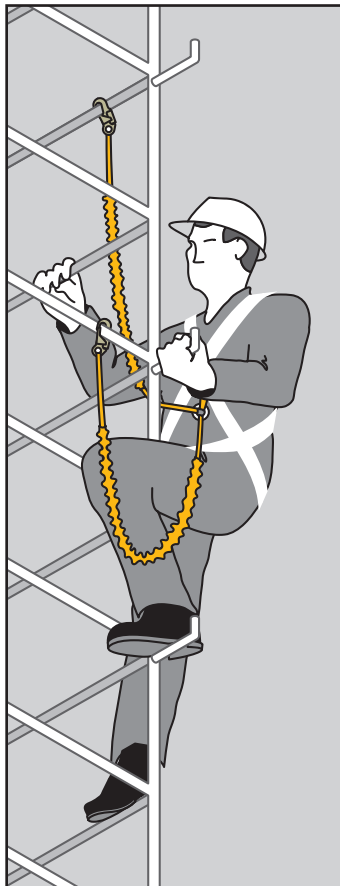
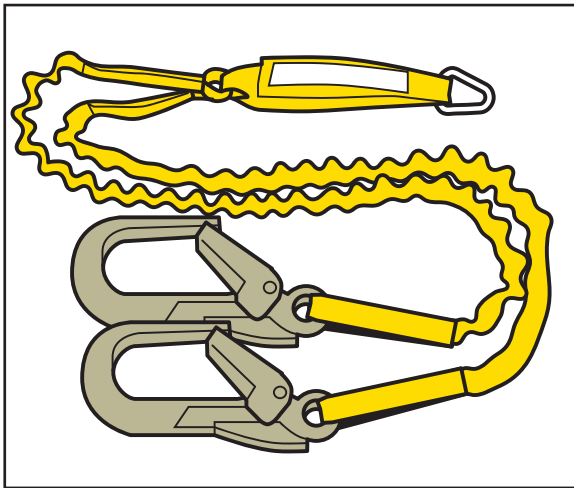

7. Ladders

Ladders are primarily a means of access and egress. Many falls take place when people are working from ladders. In addition, when using a ladder:

- the working width and movement is limited
- the time involved in moving and setting up ladders is often underestimated when planning work
- the working position on ladders is often uncomfortable (the need to stretch sideways, work above shoulder height and stand on narrow rungs for a long time) and may cause musculoskeletal disorders.

For these reasons, you should consider whether an elevating work platform or scaffolding would be safer and more efficient.

7.1 Portable ladders

Extension or single ladders should generally only be used as a means of access to or egress from a work area. They should only be used as a working platform for light work of short duration that can be carried out safely on the ladder.

Selecting ladders

If ladders are used they must be selected to suit the task to be undertaken. In doing this, you should consider the duration of the task, the physical surroundings of where the task is to be undertaken and the prevailing weather conditions.

Ladders should have a load rating of at least 120 kg and be manufactured for industrial use.

Positioning ladders

Any ladder used at a workplace must be set up on a solid and stable surface, and set up so as to prevent the ladder from slipping. Single and extension ladders can be prevented from slipping by:

- placing ladders at a slope of 4:1, and setting up stepladders in the fully opened position
- securing ladders at the top or bottom, or if necessary, at both ends (see Figure 27).

Figure 27

Some effective ways of securing a ladder.

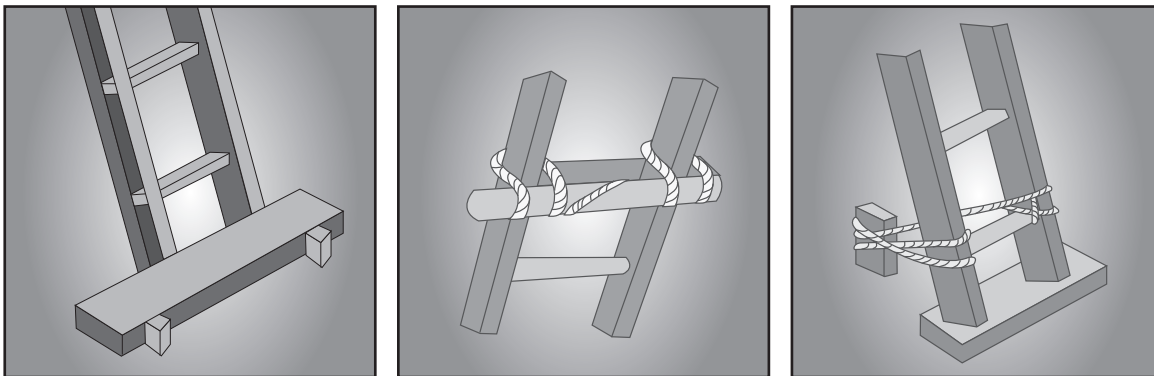
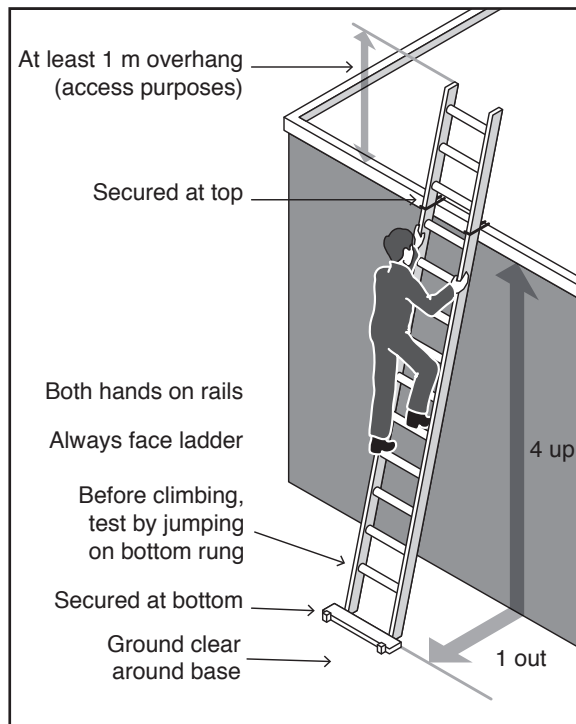

Figure 28

Example of acceptable ladder use.



Access or egress

Where fixed or extension ladders are used for access or egress, you should check that:

- there is a firm, stable work platform, free from obstructions, to step onto from the ladder
- the ladder extends at least one metre above the stepping-off point on the working platform
- fall protection is provided at the stepping-off point where people access the working platform.

Safe Use of Ladders

When a ladder is used, you should check that:

- the ladder is in good condition – the ladder should be inspected for faults, such as broken rungs, stiles and footing before it is used
- damaged ladders are removed from service
- the ladder is set up on firm, stable and level ground
- the ladder is the correct height for the task to avoid reaching or stretching
- the ladder is not too close or too far from the support structure – the distance between the ladder base and the supporting structure should be about one metre for every four metres of working ladder height (4:1 ratio)
- the ladder is secured against displacement (ie slipping or sliding) and/or there is another person holding the base of the ladder
- the ladder is not placed so that the weight of the ladder and any person using the ladder is supported by the rungs
- all the locking devices on the ladder are secure
- materials or tools are not carried while climbing the ladder – use a tool belt or side pouch
- only light duty work is undertaken while on the ladder, where three points of contact can be maintained and

- tools can be operated safely with one hand
- slip resistant base, rungs or steps are provided
 - slip resistant shoes are worn
 - ladders are not used without additional appropriate precautions:
 - in access areas or doorways – if necessary, erect a barrier or lock the door shut
 - on scaffolding or an elevating work platform to get extra height
 - next to power lines unless the worker is trained and authorised and the appropriate ladder is being used
 - in very wet or windy conditions
 - next to traffic areas, unless the working area is barricaded.

Figure 29

A step platform can provide a stable work surface.



When using ladders, it is not safe to:

- use metal or metal reinforced ladders when working on live electrical installations
- carry out work such as arc welding or oxy cutting
- work over other people
- allow anyone else to be on the ladder at the same time.

Except where additional and appropriate fall protection equipment is used in conjunction with the ladder, it is not safe to:

- use a stepladder near the edge of an open floor, penetration or beside any railing
- over-reach (the centre of the torso should be within the ladder stiles throughout the work)
- use any power or hand tool requiring two hands to operate, such as concrete cutting saws and circular saws
- use tools that require a high degree of leverage force which, if released, may cause the user to over-balance or fall from the ladder, such as pinch bars

- face away from the ladder when going up or down, or when working from it
- stand on a rung closer than 900 mm to the top of a single or extension ladder
- stand higher than the second tread below the top plate of any stepladder (with the exception of three-rung step ladders).

Guidance on the selection, safe use and care of portable ladders is set out in AS/NZS 1892 *Portable ladders* series. The manufacturer's recommendations on safe use should also be followed.

Figure 30

Examples of unsafe ladder use.

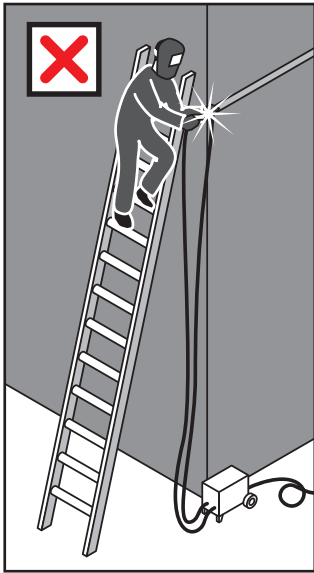

Performing hot work from ladder.

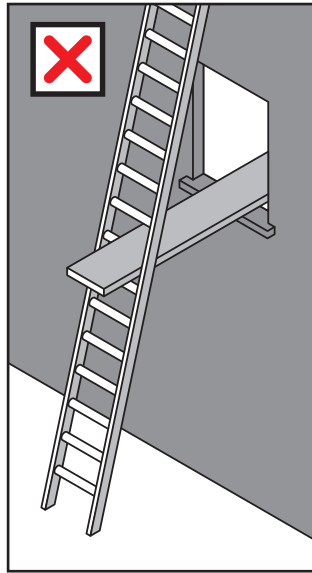

Ladder set up incorrectly.

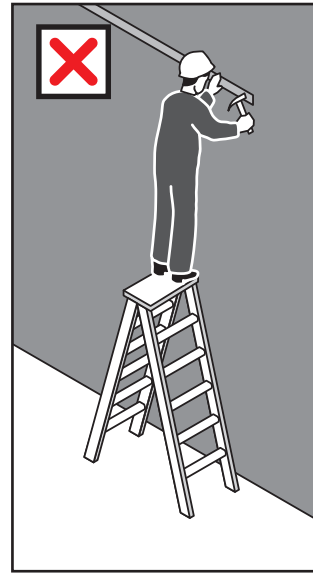

Standing on top of stepladder.

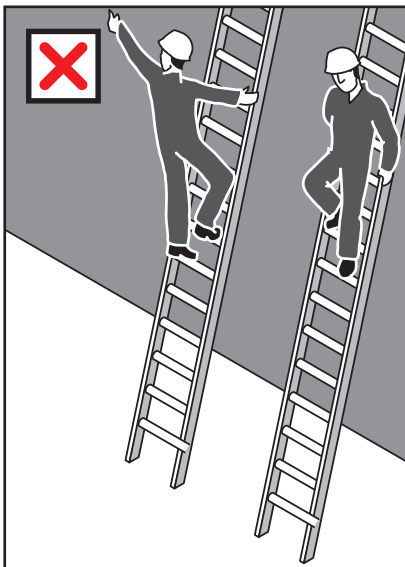

Facing away from the ladder to descend; over-reaching.

7.2 Fixed ladders

Fixed ladders should be installed in accordance with AS 1657 *Fixed Platforms, Walkways, Stairways and Ladders – Design, Construction and Installation*.

Ladder cages in fixed ladders do not stop a fall but simply funnel a fall and, in some cases, more injuries can occur from striking the protective backguards on the way down. The cages may also hinder rescues. Therefore, fixed ladders with angles exceeding 75 degrees to the horizontal should be fitted with a permanent or temporary fall-arrest system (anchorage lines or rails).

The angle of slope should not be less than 70 degrees to the horizontal and not greater than 75 degrees to the horizontal. **In no case should the ladder overhang the person climbing the ladder.** If the angle is more than 75 degrees, a safe system of work to prevent falls should be provided such as a permanent fall-arrest system or a full body harness with double arm lanyard.

A specifically designed rescue procedure should be developed for use in ladder cage situations. Training in rescue procedures should occur before using the fixed ladder.

Figure 31

Example of a fixed ladder fitted with a ladder cage.

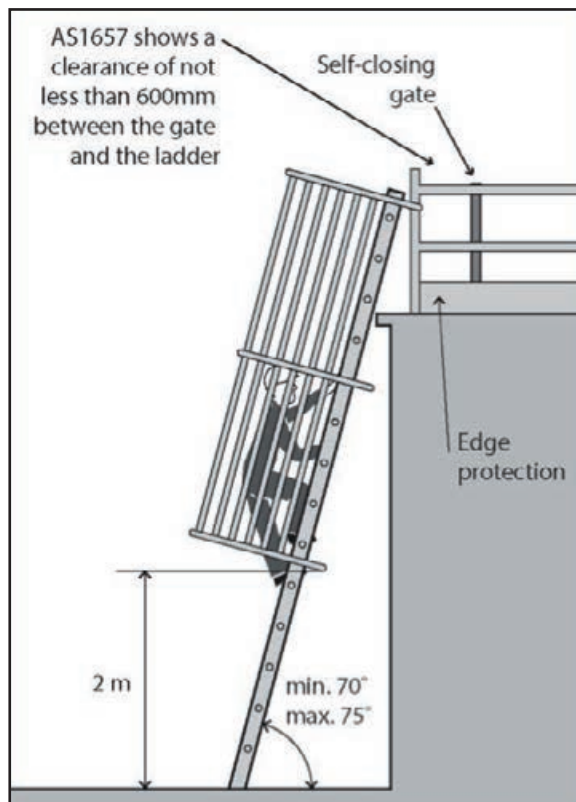

7.3 Ladder maintenance

Ladders should be regularly inspected by a competent person in accordance with the manufacturer's recommendations. Ladders with any of the following faults must be replaced or repaired:

- fibreglass stiles cracked, chipped or severely faded with fibres exposed
- timber stiles warped, splintered, cracked or bruised
- metal stiles twisted, bent, kinked, crushed or with cracked welds or damaged feet
- rungs, steps, treads or top plates that are missing, worn, damaged or loose
- tie rods missing, broken or loose
- ropes, braces, or brackets that are missing, broken or worn
- timber members that are covered with opaque paint or other treatment that could disguise faults in the timber
- missing, loose, bent or worn fasteners, ie rivets, bolts and pins
- worn or damaged feet, including non-slip material.

8. Administrative controls

Administrative controls may be used to support other control measures and may include 'no go' areas, permit systems, the sequencing of work and safe work procedures. Using administrative controls exclusively to minimise the risk of falls is only appropriate when it is not reasonably practicable to use a higher order control.

'No go' areas

'No go' areas can be an effective method of making sure people are not exposed to hazards. They require clear signs warning people not to access the hazardous area. They can be used to highlight the risks of entry to an area where there is an unguarded hazard, or to areas where work is being undertaken overhead and there is a risk of falling objects.

Relevant information and instruction should be provided about 'no go' areas with adequate supervision to ensure that no unauthorised worker enters the 'no go' area.

Barriers should be used in conjunction with signs to cordon-off areas where there is a risk of falling or being hit by falling objects. They should be highly visible and securely fixed to prevent displacement.

Permit systems

Permit systems allow only competent persons trained in the use of relevant control measures to work in an area where there is a hazard. Examples include:

- tagging all access points to a scaffold to restrict unauthorised access during erection and dismantling, with 'only licensed scaffolders permitted on an incomplete scaffold'
- requiring permits for access to areas where travel restraint systems or fall-arrest systems are to be used.

Organising and sequencing of work

Work should be organised so that people do not interfere with other workers or increase the risk to themselves or others. For example, you can sequence jobs so that different trades are not working above or below each other at the same time. Plan the work so tasks are not performed for extended periods from a ladder, or so that work at height is minimised in extremely hot or cold weather.

Safe work procedures

An administrative control may be as simple as a safe work procedure that describes the steps involved in safely undertaking a task. It may also include any particular training, instruction and the level of supervision required. For example, a safe work procedure to reduce the risk of falls when entering or exiting vehicles may include instructing drivers to not jump down from the cab and always maintain three points of contact when climbing into or out of the cab (see Figure 33).

If relying on administrative controls, it may be necessary to provide a high level of supervision to ensure that the safe work procedure is being adhered to.

Figure 32

Example of a sign for a 'no go' area.



Figure 33

Diagrams showing the correct procedure for climbing in and out of trucks.

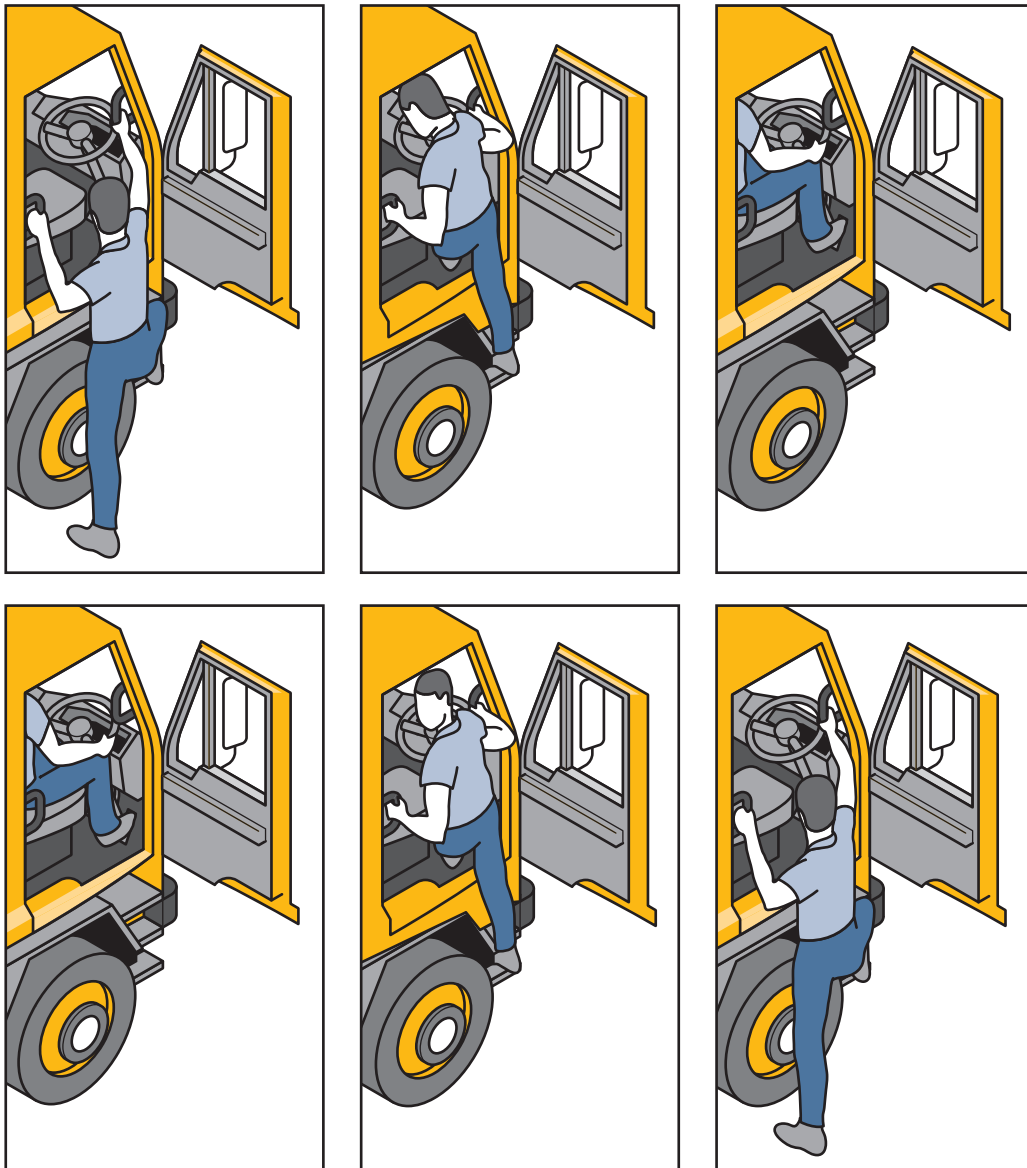

9. Emergency procedures for falls

Whenever there are risks from working at height, appropriate emergency procedures and facilities, including first aid, must be established and provided. Typical injuries from falls can include unconsciousness and occluded airway, impalement, serious head or abdominal injuries and fractures.

A person using a fall-arrest system could suffer suspension intolerance as a result of a fall. The WHS Regulations contain a specific provision to address the need for emergency and rescue procedures for such situations.

Regulation 80

A person conducting a business or undertaking who implements a fall-arrest system as a measure to control risk must establish emergency and rescue procedures.

The procedures must be tested so that they are effective. Workers must be provided with suitable and adequate information, instruction and training in relation to the emergency procedures.

9.1 Emergency procedures

In developing emergency procedures, the different types of emergency and rescue scenarios that might arise should be considered. Information from the risk assessment will help in this task.

Regulation 42

You must ensure that workers have access to first aid equipment and facilities for the administration of first aid. You must also ensure that workers are trained to administer first aid or that workers have access to persons who are trained in first aid.

Further guidance is available in the *First Aid in the Workplace Code of Practice [under development]*.

The emergency procedures for falls may be incorporated into the emergency plan required for the workplace under the WHS Regulations.

When establishing emergency procedures, you should take into account the following:

Relevant considerations	Questions
Location of the work area	<p>Is the work at height being undertaken in a remote or isolated place? How accessible is it in an emergency and how far away is it from appropriate medical facilities?</p> <p>Can the rescue of a person after an arrested fall be provided immediately, without the need to rely on emergency services?</p>
Communications	How can workers working at height communicate in an emergency?
Rescue equipment	<p>What kinds of emergencies may arise? The provision of suitable rescue equipment will depend on the nature of the work and the control measures used, for example, an emergency rapid response kit with man-made fibre rope, according to AS/NZS 4142.3 <i>Fibre ropes – Man-made fibre rope for static life rescue lines</i>.</p> <p>Selected rescue equipment should be kept in close proximity to the work area so that it can be used immediately.</p>
Capabilities of rescuers	<p>Are rescuers properly trained, sufficiently fit to carry out their task and capable of using any equipment provided for rescue (eg breathing apparatus, lifelines and fire-fighting equipment)?</p> <p>Have emergency procedures been tested to demonstrate that they are effective?</p>
First aid	<p>Is appropriate first aid available for injuries associated with falls?</p> <p>Are trained first aiders available to make proper use of any necessary first aid equipment?</p>
Local emergency services – if they are to be relied on for rescue	How will the local emergency services (eg ambulance) be notified of an incident? What is the likely response time?

9.2 Suspension intolerance

Suspension intolerance can occur with a fall-arrest system when a person has an arrested fall and is suspended in an upright, vertical position with the harness straps causing pressure on the leg veins. The lower legs' capacity to store large amounts of blood reduces the return of blood to the heart, slowing the heart rate, which can cause the person to faint. This may lead to renal failure and eventually death, depending on a person's susceptibility. This condition may be worsened by heat and dehydration.

The quick rescue of a person suspended in a full body harness, as soon as is possible, is vital. For this reason, workers should be capable of conducting a rescue of a fallen worker and be familiar with onsite rescue equipment and procedures.

Workers and emergency response workers must be trained in the rescue procedures and be able to recognise the risks of suspension intolerance and act quickly in the rescue of a person.

Preventing suspension intolerance

To prevent suspension intolerance occurring as a result of an arrested fall, you should ensure that:

- workers never work alone when using a harness as fall protection
- workers use a harness, which allows legs to be kept horizontal
- the time a worker spends in suspension after a fall is limited to less than five minutes. When a suspension is longer than five minutes, foothold straps or a way of placing weight on the legs should be provided.
- workers are trained to do the following when they are hanging in their harness after a fall:
 - move their legs in the harness and push against any footholds, where these movements are possible. In some instances, the harness design and/or any injuries received may prevent this movement
 - move their legs as high as possible and the head as horizontal as possible, where these movements are possible.

Training for rescues

The training for rescuing workers who have fallen should address the following factors:

- the rescue process should start immediately
- training frequency should take into account the worker's competence and their ability to retain competence through regular exposure to the equipment and skills needed to perform a rescue
- workers should not put themselves at risk during a rescue.

10. Design of plant and structures

10.1 Design considerations

Consideration of the potential risk of falls early when designing plant or structures can result in the elimination of such risks. Where elimination is not possible, one way to minimise risks at the design stage is to integrate fall prevention systems into the design.

Safety considerations at the design stage should include:

- safe entry to and exit from any work area
- designing permanent guard rails or other forms of edge protection (for example, parapet walls) for permanent fall prevention on roofs
- future maintenance requirements, especially in relation to sloping building exteriors and windows, to ensure maintenance can be carried out safely
- specifying the strength of roof members and other points to which guard rail, or anchor points for work positioning systems will be fixed
- safer building design generally, with, for example:
 - low-level mounting of roof vents
 - the location of air conditioning units and other roof-mounted plant, such as satellite dishes, away from edges
 - the location of air conditioning and similar plant at ground level
 - the specification of non-fragile material for the roof
 - the use of permanent safety mesh
 - safer gutters, for example, installing large volume gutters and down pipes to minimise the need to access the roof for cleaning, locating the gutters at ground level or away from edges, or the removal of gutters altogether, with a smooth transition from the roof to the walls with the gutters at ground level.
- specific safety requirements for particular workers doing subsequent installation, maintenance or repair work. These groups include:
 - people installing and maintaining antennae and satellite dishes
 - contractors servicing air conditioning equipment on the roof
 - window and gutter cleaners and repairers
- designing the pre-fabrication of structures on the ground before they are lifted into position.

10.2 Plant

Safety considerations at the design stage could include:

- providing adequate steps and hand rails on vehicles (see Figure 34)
- incorporating a fall prevention system in silos and overhead conveyors
- ensuring workers who will be maintaining or cleaning the plant are able to do so safely
- considering the safety of passengers.

Section 22

Designers must provide information to each person who is provided with the design that includes information on the purpose for which the plant was designed and how to use the plant safely.

Figure 34

Dump trucks.

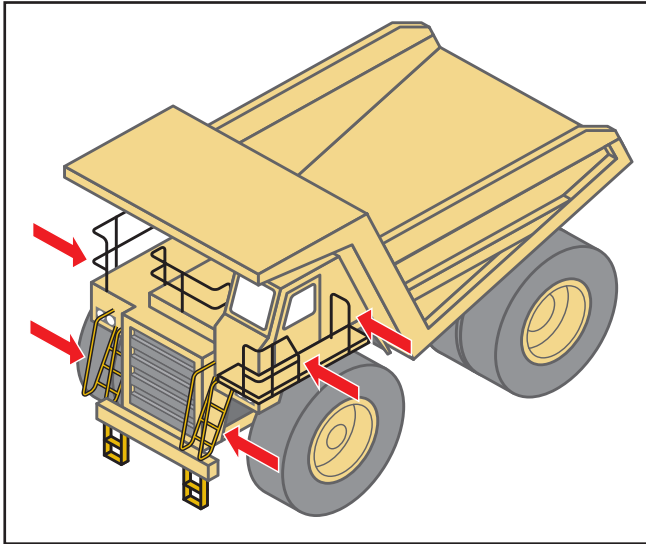

10.3 Buildings and structures

Designers or constructors of buildings or structures must ensure, so far as is reasonably practicable, that workers involved with the construction, use or subsequent maintenance are not exposed to the risks associated with work at height. Therefore, at the design and planning stage, it is important to consider providing fall prevention systems as part of the building or structure.

As it is unlikely that all design work on larger projects will be carried out by one designer, consultation, co-operation and co-ordination should occur between the builder and other designers to ensure the safe interaction of the different design aspects.

When risks remain in the design work, information must be included with the design to alert others to the risks. Providing information about safety issues is a key component to ensure proper, adequate and suitable design and installation.

The design and planning for the construction stage should include:

- reducing the risk for those working at heights, such as the installation of guard rails to perimeter structural members prior to erection
- reducing the time spent working at heights by pre-fabricating modules on the ground, before lifting them into position
- sequencing of the work to be performed at heights
- the location and condition of access roads, for example to enable a crane to place building materials in the most appropriate and accessible location, rather than the materials being moved manually
- preparation of the ground or floor below the work area. It should be compacted and level to support plant or equipment, such as cranes and scissor lifts
- identification of underground services including drainage, for example for the safe setting up of cranes
- provision of permanent safety mesh.

Planning for building maintenance

During the planning stage, consideration should also be given to the methods by which maintenance, repairs or cleaning will be undertaken on a building or structure, for example:

- designing window cleaning bays or gangways integrated into the structural frame
- designing permanent anchorage and hoisting points into structures where maintenance needs to be undertaken at height.

Planning the site layout

When planning the site layout, the following factors should be considered:

- the preparation of firm, level surfaces below work areas for the support of plant and equipment, such as scissor lifts or mobile scaffolds
- the site and condition of access roads to enable plant to place material in and pick it up from the most favourable positions, thereby reducing, for example, the need for manual handling at height
- safe access to and egress from work areas and amenities, including the provision and placement of stairways, ladders, catwalks, guardrails and barriers
- the need for adequate means of escape and rescue in the event of an emergency.

Appendix A: Terms used in fall control measures

Anchorage: means a secure point for attaching a lanyard, lifeline or other component of a travel restraint system or fall-arrest system. Anchorages require specific load and impact capacities for their intended use.

Double or triple action device: is a self-closing hook or karabiner with a keeper latch which will automatically close and remain closed until manually opened. These units have a minimum of at least two distinct and deliberate consecutive actions to manually open them.

Free fall: is any fall or part of a fall where the person falling is under the unrestrained influence of gravity over any fall distance, either vertically or on a slope on which it is not possible to walk without the assistance of a handrail or hand line.

Inertia reel: (also known as a self-retracting lanyard or fall-arrest block) is a type 2 or 3 fall-arrest device that arrests a fall by locking onto a line and at the same time allows freedom of movement.

Karabiners: these are metal types of connectors that can be attached to anchorage points. They come in a variety of sizes, shapes and locking mechanisms to suit various applications. They should be self-closing and self-or manual-locking and capable of being opened only by at least two consecutive deliberate manual actions.

Lanyard: an assembly consisting of a line and components which will enable connection between a harness and an anchorage point and will absorb energy in the event of a fall.

Personal energy absorber (or deceleration device): means a device which reduces the deceleration force imposed when a fall is suddenly arrested, and correspondingly reduces the loadings on the anchorage and the person's body. The energy absorber may either be a separate item or manufactured as part of the lanyard.

Restraint line: is the line securing workers to a point of anchorage and is used to prevent a person from reaching a point from which he or she could fall.

Static line: is a horizontal or substantially horizontal line to which a lanyard may be attached and which is designed to arrest a free fall.

Total fall distance: is the total distance a person is likely to fall during both the free and restrained parts of a fall and includes the maximum dynamic extension of all supporting components.

Appendix B: References and other information sources

Australian Standards and Australian/New Zealand Standards

AS 1418.13	<i>Cranes (including Hoists and Winches) – Building Maintenance Units</i>
AS/NZS 1576	<i>Scaffolding series</i>
AS/NZS 1657	<i>Fixed platforms, walkways, stairways and ladders – Design, construction and installation</i>
AS/NZS 1891.1	<i>Industrial fall-arrest systems and devices – Harnesses and ancillary equipment</i>
AS/NZS 1891.2	<i>supp:1-2001 Industrial fall-arrest systems and devices – Horizontal lifeline and rail systems – Prescribed configurations for horizontal lifelines (Supplement to AS/NZS 1891.2:2001)</i>
AS/NZS 1891.3	<i>Industrial fall-arrest systems and devices – Fall-arrest devices</i>
AS/NZS 1891.4	<i>Industrial fall-arrest systems and devices – Selection, use and maintenance</i>
AS/NZS 1892	<i>Portable ladders series</i>
AS/NZS 4142.3	<i>Fibre ropes – Man-made fibre rope for static life rescue lines</i>
AS/NZS 4389	<i>Safety mesh</i>
AS/NZS 4488	<i>Industrial rope access systems series</i>
AS/NZS 4488.2	<i>Industrial rope access systems – Selection, use and maintenance</i>
AS/NZS 4576	<i>Guidelines for scaffolding</i>
AS 2550.16	<i>Cranes – Safe Use – Mast climbing work platforms</i>
AS/NZS 4994	Temporary edge protection series
Available from:	SAI Global Limited Business Publishing GPO Box 5420, Sydney, NSW, 2001 Tel.: 131 242 or 02 8206 6000 Email: mail@saiglobal.com Internet address: saiglobal.com.au

British Standards Institution

BSEN 1263-1:2002	<i>Safety nets: Safety requirements, test methods</i>
BSEN 1263-2:2002	<i>Safety nets: Safety requirements for the positioning limits</i>
Internet address:	bsi-global.com

List of amendments

Date	Location	Amendments
31 July 2015	Front cover	Publication date changed from December 2011 to republished date of July 2015.
31 July 2015	Inside cover	The 'NSW Note' includes a reference to the new amendments as contained in the list of amendments.
31 July 2015	Table of contents	The table of contents references this list of amendments.
31 July 2015	Section 1.1	Chapter reference amended to Chapter 10.
31 July 2015	Section 6.3	Figure 21 – The maximum energy absorber extension measurement changed from 1.9m to 1.7m.
31 July 2015	Section 7.2	Figure 31 adjusted so the self-closing gate is not at the top of the access ladder.
1 April 2016	Figure 28	The following text has been added within the figure: 'Before climbing, test by jumping on bottom rung'.
1 April 2016	Front cover	Publication date changed from July 2015 to republished date of April 2016.

Disclaimer

This publication may contain information about the regulation and enforcement of work health and safety in NSW. It may include some of your obligations under some of the legislation that SafeWork NSW administers. To ensure you comply with your legal obligations you must refer to the appropriate legislation.

Information on the latest laws can be checked by visiting the NSW legislation website legislation.nsw.gov.au

This publication does not represent a comprehensive statement of the law as it applies to particular problems or to individuals or as a substitute for legal advice. You should seek independent legal advice if you need assistance on the application of the law to your situation.

This material may be displayed, printed and reproduced without amendment for personal, in-house or non-commercial use.

©SafeWork NSW

This code provides practical guidance to persons conducting a business or undertaking, including those persons who design, construct, import, supply or install plant or structures, on how to manage health and safety risks arising from falls.

Catalogue No. **SW08159**
SafeWork NSW, 92–100 Donnison Street, Gosford, NSW 2250
Locked Bag 2906, Lisarow, NSW 2252 | Customer Service Centre **13 10 50**
Website safework.nsw.gov.au
©Copyright SafeWork NSW 0316
